

Stikkontrol • Stechkontrolle • StICK control

**VISSTIK**

**NEWS**

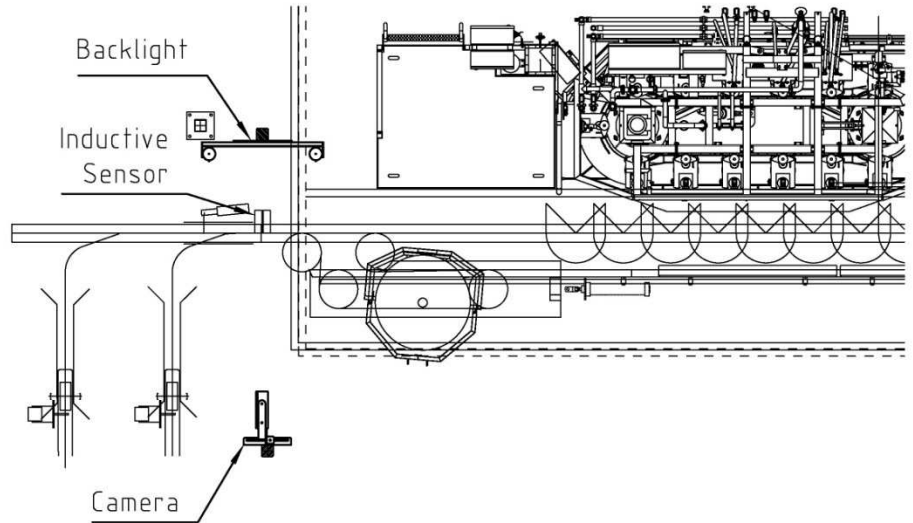

- Automatic stick control to assure that all pigs have been stuck correctly.
- Avoid live pigs in the scalding process.
- Easy to install and no down time.
- The patented system is based on vision technology.
- The system consists of a camera which by means of a lamp with constant backlight takes two images of each pig. Software controls if blood is running from the pig.
- If Pic. 1 = Pic. 2 the conveyor automatically stops for manual control and sticking.
- Interface to remote PC
- Automatic alarm and stop of line
- Capacity: 1400 pigs per hour

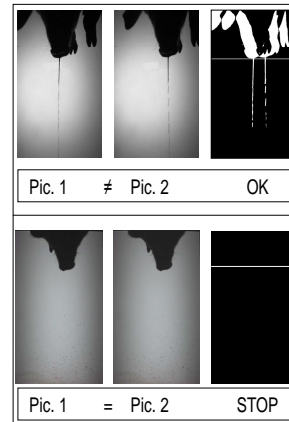

**Welfare matters**

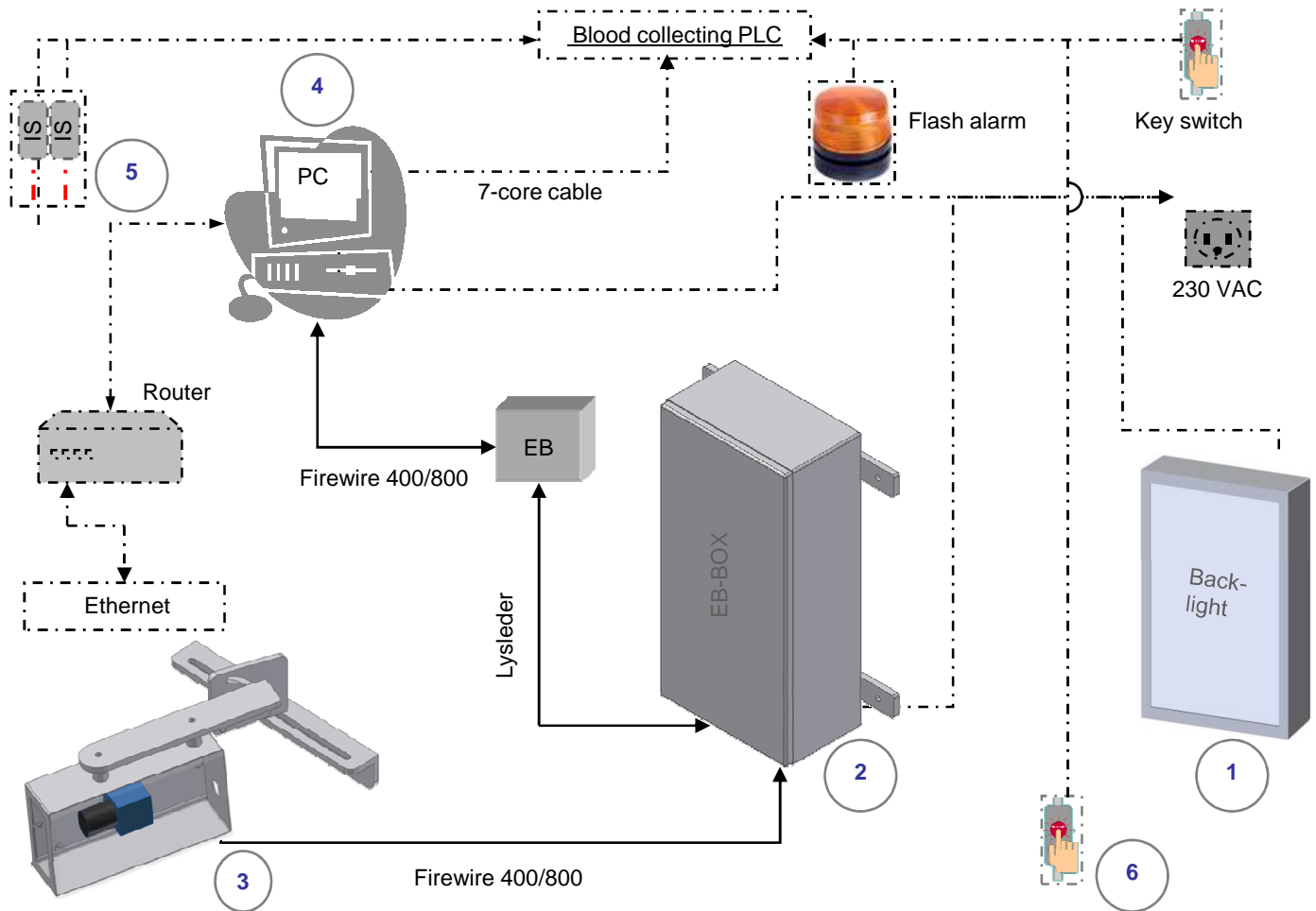

1 = Backlight, 2 = Extender box, 3 = Camera box, 4 = PC, 5 = Inductive sensors, 6 = Alarm receipt button

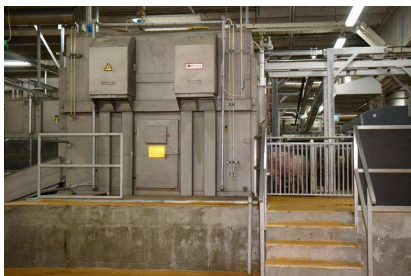

**Butina & Anitec**

The suppliers of complete solutions consisting of:

*Pigs handling systems;  
CO2 stunning systems;  
Blood collection systems;  
Blood processing systems.*

Both companies are characterized by being the world leaders in their specialized fields, more than 800 systems have been installed at slaughter houses in more than 50 countries



**Anitec**<sup>®</sup>  
Box 4427, SE-203 15 Malmö  
Tel: +46 40 737 40  
www.anitec.se

**Butina**<sup>®</sup>  
Ydervang 5, DK-4300 Holbaek  
Tel: +45 59 450 450  
www.butina.dk

**mps**<sup>®</sup>  
meat processing systems